

The LTE Network Architecture

A comprehensive tutorial

Long Term Evolution (LTE) is the latest buzzword on everyone's lips, but are you as conversant with the LTE architecture as you would like to be, or — more importantly — need to be? Would you like to find out more about LTE, but have little time to devote to it? If so, this paper will help get you up to speed in no time. Originally published as a chapter in the most comprehensive LTE reference book available, *LTE — The UMTS Long Term Evolution: From Theory to Practice* (Wiley 2009), this paper provides a short, but comprehensive, overview of the 3GPP Release 8 LTE network architecture and interfaces, showing how it can be deployed in an optimized and efficient manner. Engineers involved in the design of LTE interfaces and network equipment, as well as those involved in the first deployments of this new technology, should find this paper invaluable.

Table of contents

1	1. Executive summary
1	2. Introduction
1	3. Overall architectural overview
3	3.1 The core network
5	3.2 The access network
6	3.3 Roaming architecture
6	3.4 Interworking with other networks
7	4. Protocol architecture
7	4.1 User plane
8	4.2 Control plane
8	5. Quality of service and EPS bearers
11	5.1 Bearer establishment procedure
12	6. The E-UTRAN network interfaces: S1 interface
12	6.1 Protocol structure over S1
13	6.2 Initiation over S1
14	6.3 Context management over S1
14	6.4 Bearer management over S1
14	6.5 Paging over S1
15	6.6 Mobility over S1
16	6.7 Load management over S1
17	7. The E-UTRAN network interfaces: X2 interface
17	7.1 Protocol structure over X2
17	7.2 Initiation over X2
18	7.3 Mobility over X2
21	7.4 Load and interference management over X2
22	7.5 UE historical information over X2
22	8. Summary
22	9. Abbreviations
23	10. Contacts
23	11. References

1. Executive summary

This paper provides a comprehensive overview of the network architecture of a Long Term Evolution (LTE) system according to the Release 8 version of the specifications. It is designed to enable the reader to become conversant rapidly with the main principles of the LTE network architecture. Engineers involved in the design of LTE interfaces and network equipment, as well as those involved in the first deployments of this new technology, should find this paper invaluable.

Not only does this paper provide a straightforward introduction to the definitive but complex specifications defined by the Third-Generation Partnership Project (3GPP), but it also particularly highlights aspects of the network architecture and interfaces that enable LTE networks to be deployed in an optimized and efficient manner. References are provided throughout so that the interested reader can readily access more detailed material.

The content of this paper, authored by Sudeep Palat and Philippe Godin, was originally published as an invited chapter in the book *LTE — The UMTS Long Term Evolution: From Theory to Practice* (Wiley 2009), edited by Stefania Sesia, Issam Toufik and Matthew Baker, which is widely recognized as the most comprehensive reference book available on LTE. Sudeep Palat, Philippe Godin and Matthew Baker are all lead representatives in Alcatel-Lucent's 3GPP standardization team.

2. Introduction

In contrast to the circuit-switched model of previous cellular systems, Long Term Evolution (LTE) has been designed to support only packet-switched services. It aims to provide seamless Internet Protocol (IP) connectivity between user equipment (UE) and the packet data network (PDN), without any disruption to the end users' applications during mobility.

While the term "LTE" encompasses the evolution of the Universal Mobile Telecommunications System (UMTS) radio access through the Evolved UTRAN (E-UTRAN), it is accompanied by an evolution of the non-radio aspects under the term "System Architecture Evolution" (SAE), which includes the Evolved Packet Core (EPC) network. Together LTE and SAE comprise the Evolved Packet System (EPS).

EPS uses the concept of EPS bearers to route IP traffic from a gateway in the PDN to the UE. A bearer is an IP packet flow with a defined quality of service (QoS) between the gateway and the UE. The E-UTRAN and EPC together set up and release bearers as required by applications.

This paper provides a comprehensive tutorial of the overall EPS network architecture, giving an overview of the functions provided by the core network (CN) and E-UTRAN. The protocol stack across the different interfaces is explained, along with an overview of the functions provided by the different protocol layers. The end-to-end bearer path along with QoS aspects are also discussed, including a typical procedure for establishing a bearer. The remainder of this paper presents the network interfaces in detail, with particular focus on the E-UTRAN interfaces and the procedures used across these interfaces, including those for the support of user mobility.

3. Overall architectural overview

EPS provides the user with IP connectivity to a PDN for accessing the Internet, as well as for running services such as Voice over IP (VoIP). An EPS bearer is typically associated with a QoS. Multiple bearers can be established for a user in order to provide different QoS streams or connectivity to different PDNs. For example, a user might be engaged in a voice (VoIP) call while at the same time performing web browsing or FTP download. A VoIP bearer would provide the necessary QoS for the voice call, while a best-effort bearer would be suitable for the web browsing or FTP session.

The network must also provide sufficient security and privacy for the user and protection for the network against fraudulent use.

Figure 1. The EPS network elements

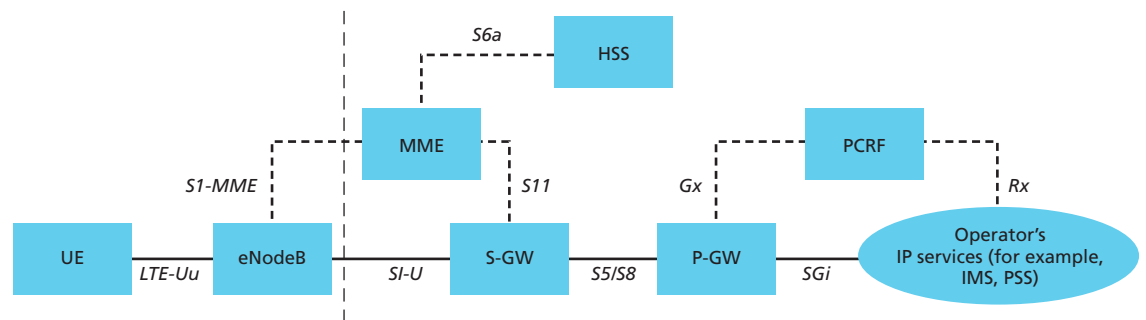

This is achieved by means of several EPS network elements that have different roles. Figure 1 shows the overall network architecture, including the network elements and the standardized interfaces. At a high level, the network is comprised of the CN (EPC) and the access network E-UTRAN. While the CN consists of many logical nodes, the access network is made up of essentially just one node, the evolved NodeB (eNodeB), which connects to the UEs. Each of these network elements is interconnected by means of interfaces that are standardized in order to allow multi-vendor interoperability. This gives network operators the possibility to source different network elements from different vendors. In fact, network operators may choose in their physical implementations to split or merge these logical network elements depending on commercial considerations. The functional split between the EPC and E-UTRAN is shown in Figure 2. The EPC and E-UTRAN network elements are described in more detail below.

Figure 2. Functional split between E-UTRAN and EPC

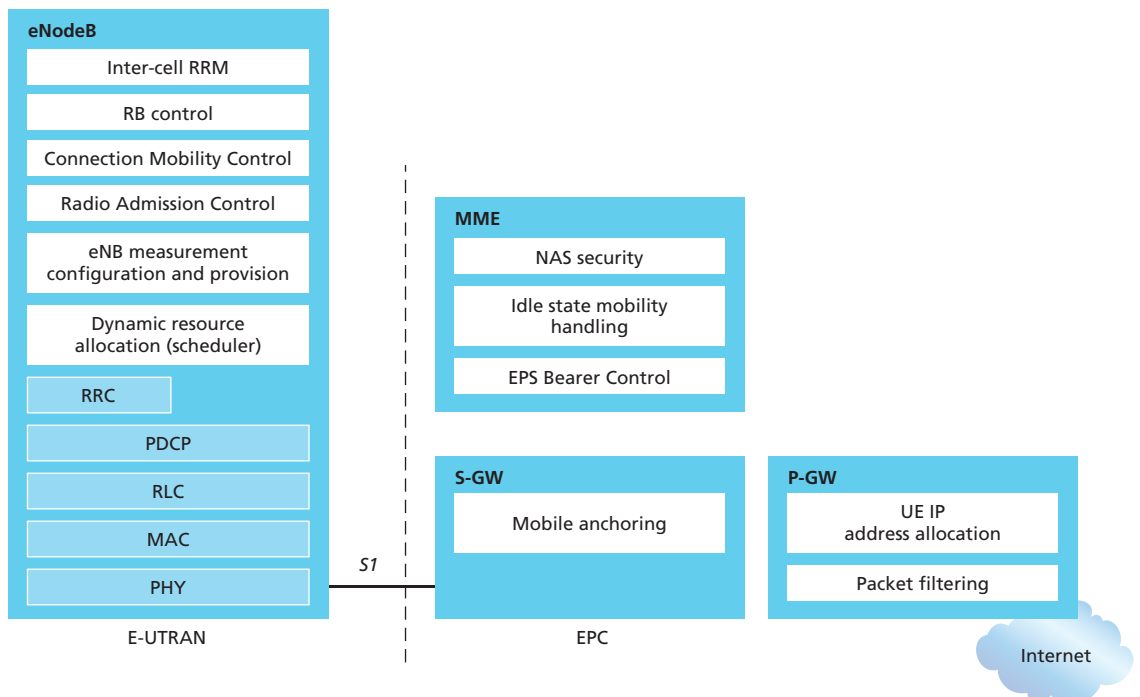

3.1 The core network

The core network (called EPC in SAE) is responsible for the overall control of the UE and establishment of the bearers. The main logical nodes of the EPC are:

- PDN Gateway (P-GW)
- Serving Gateway (S-GW)
- Mobility Management Entity (MME)

In addition to these nodes, EPC also includes other logical nodes and functions such as the Home Subscriber Server (HSS) and the Policy Control and Charging Rules Function (PCRF). Since the EPS only provides a bearer path of a certain QoS, control of multimedia applications such as VoIP is provided by the IP Multimedia Subsystem (IMS), which is considered to be outside the EPS itself.

The logical CN nodes are shown in Figure 1 and discussed in more detail below:

- *PCRF* – The Policy Control and Charging Rules Function is responsible for policy control decision-making, as well as for controlling the flow-based charging functionalities in the Policy Control Enforcement Function (PCEF), which resides in the P-GW. The PCRF provides the QoS authorization (QoS class identifier [QCI] and bit rates) that decides how a certain data flow will be treated in the PCEF and ensures that this is in accordance with the user's subscription profile.
- *HSS* – The Home Subscriber Server contains users' SAE subscription data such as the EPS-subscribed QoS profile and any access restrictions for roaming. It also holds information about the PDNs to which the user can connect. This could be in the form of an access point name (APN) (which is a label according to DNS naming conventions describing the access point to the PDN) or a PDN address (indicating subscribed IP address(es)). In addition the HSS holds dynamic information such as the identity of the MME to which the user is currently attached or registered. The HSS may also integrate the authentication center (AUC), which generates the vectors for authentication and security keys.
- *P-GW* – The PDN Gateway is responsible for IP address allocation for the UE, as well as QoS enforcement and flow-based charging according to rules from the PCRF. It is responsible for the filtering of downlink user IP packets into the different QoS-based bearers. This is performed based on Traffic Flow Templates (TFTs). The P-GW performs QoS enforcement for guaranteed bit rate (GBR) bearers. It also serves as the mobility anchor for interworking with non-3GPP technologies such as CDMA2000 and WiMAX® networks.
- *S-GW* – All user IP packets are transferred through the Serving Gateway, which serves as the local mobility anchor for the data bearers when the UE moves between eNodeBs. It also retains the information about the bearers when the UE is in the idle state (known as "EPS Connection Management — IDLE" [ECM-IDLE]) and temporarily buffers downlink data while the MME initiates paging of the UE to reestablish the bearers. In addition, the S-GW performs some administrative functions in the visited network such as collecting information for charging (for example, the volume of data sent to or received from the user) and lawful interception. It also serves as the mobility anchor for interworking with other 3GPP technologies such as general packet radio service (GPRS) and UMTS.
- *MME* – The Mobility Management Entity (MME) is the control node that processes the signaling between the UE and the CN. The protocols running between the UE and the CN are known as the Non Access Stratum (NAS) protocols.

The main functions supported by the MME can be classified as:

- *Functions related to bearer management* – This includes the establishment, maintenance and release of the bearers and is handled by the session management layer in the NAS protocol.
- *Functions related to connection management* – This includes the establishment of the connection and security between the network and UE and is handled by the connection or mobility management layer in the NAS protocol layer.

NAS control procedures are specified in [1] and are discussed in more detail in the following section.

3.1.1 Non Access Stratum procedures

The Non Access Stratum procedures, especially the connection management procedures, are fundamentally similar to UMTS. The main change from UMTS is that EPS allows concatenation of some procedures to allow faster establishment of the connection and the bearers.

The MME creates a UE context when a UE is turned on and attaches to the network. It assigns a unique short temporary identity termed the SAE Temporary Mobile Subscriber Identity (S-TMSI) to the UE that identifies the UE context in the MME. This UE context holds user subscription information downloaded from the HSS. The local storage of subscription data in the MME allows faster execution of procedures such as bearer establishment since it removes the need to consult the HSS every time. In addition, the UE context also holds dynamic information such as the list of bearers that are established and the terminal capabilities.

To reduce the overhead in the E-UTRAN and processing in the UE, all UE-related information in the access network, including the radio bearers, can be released during long periods of data inactivity. This is the ECM-IDLE state. The MME retains the UE context and the information about the established bearers during these idle periods.

To allow the network to contact an ECM-IDLE UE, the UE updates the network as to its new location whenever it moves out of its current tracking area (TA); this procedure is called a tracking area update. The MME is responsible for keeping track of the user location while the UE is in ECM-IDLE.

When there is a need to deliver downlink data to an ECM-IDLE UE, the MME sends a paging message to all the eNodeBs in its current TA, and the eNodeBs page the UE over the radio interface. On receipt of a paging message, the UE performs a Service Request procedure, which results in moving the UE to the ECM-CONNECTED state. UE-related information is thereby created in the E-UTRAN, and the radio bearers are reestablished. The MME is responsible for the reestablishment of the radio bearers and updating the UE context in the eNodeB. This transition between the UE states is called an idle-to-active transition. To speed up the idle-to-active transition and bearer establishment, EPS supports concatenation of the NAS and Access Stratum (AS) procedures for bearer activation. Some interrelationship between the NAS and AS protocols is intentionally used to allow procedures to run simultaneously rather than sequentially, as in UMTS. For example, the bearer establishment procedure can be executed by the network without waiting for the completion of the security procedure.

Security functions are the responsibility of the MME for both signaling and user data. When a UE attaches with the network, a mutual authentication of the UE and the network is performed between the UE and the MME/HSS. This authentication function also establishes the security keys that are used for encryption of the bearers.

3.2 The access network

The access network of LTE, E-UTRAN, simply consists of a network of eNodeBs, as illustrated in Figure 3. For normal user traffic (as opposed to broadcast), there is no centralized controller in E-UTRAN; hence the E-UTRAN architecture is said to be flat.

The eNodeBs are normally interconnected with each other by means of an interface known as “X2” and to the EPC by means of the S1 interface — more specifically, to the MME by means of the S1-MME interface and to the S-GW by means of the S1-U interface.

The protocols that run between the eNodeBs and the UE are known as the “AS protocols.”

The E-UTRAN is responsible for all radio-related functions, which can be summarized briefly as:

- *Radio resource management (RRM)* – This covers all functions related to the radio bearers, such as radio bearer control, radio admission control, radio mobility control, scheduling and dynamic allocation of resources to UEs in both uplink and downlink.
- *Header Compression* – This helps to ensure efficient use of the radio interface by compressing the IP packet headers that could otherwise represent a significant overhead, especially for small packets such as VoIP.
- *Security* – All data sent over the radio interface is encrypted.
- *Connectivity to the EPC* – This consists of the signaling toward MME and the bearer path toward the S-GW.

On the network side, all of these functions reside in the eNodeBs, each of which can be responsible for managing multiple cells. Unlike some of the previous second- and third-generation technologies, LTE integrates the radio controller function into the eNodeB. This allows tight interaction between the different protocol layers of the radio access network (RAN), thus reducing latency and improving efficiency. Such distributed control eliminates the need for a high-availability, processing-intensive controller, which in turn has the potential to reduce costs and avoid “single points of failure.” Furthermore, as LTE does not support soft handover there is no need for a centralized data-combining function in the network.

One consequence of the lack of a centralized controller node is that, as the UE moves, the network must transfer all information related to a UE, that is, the UE context, together with any buffered data, from one eNodeB to another. Mechanisms are therefore needed to avoid data loss during handover. The operation of the X2 interface for this purpose is explained in more detail in Section 7.

Figure 3. Overall E-UTRAN architecture

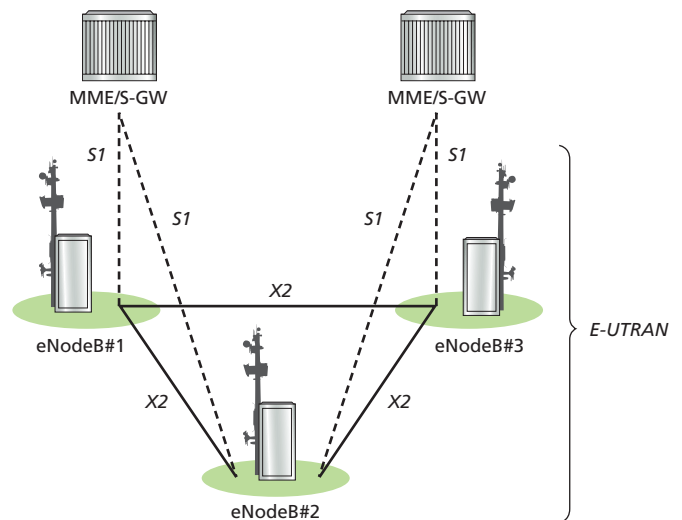

An important feature of the S1 interface linking the access network to the CN is known as “S1-flex.” This is a concept whereby multiple CN nodes (MME/S-GWs) can serve a common geographical area, being connected by a mesh network to the set of eNodeBs in that area. (See Section 6.) An eNodeB may thus be served by multiple MME/S-GWs, as is the case for eNodeB #2 in Figure 3. The set of MME/S-GW nodes that serves a common area is called an MME/S-GW pool, and the area covered by such a pool of MME/S-GWs is called a pool area. This concept allows UEs in the cell or cells controlled by one eNodeB to be shared between multiple CN nodes, thereby providing a possibility for load sharing and also eliminating single points of failure for the CN nodes. The UE context normally remains with the same MME as long as the UE is located within the pool area.

3.3 Roaming architecture

A network run by one operator in one country is known as a “public land mobile network (PLMN).” Roaming, where users are allowed to connect to PLMNs other than those to which they are directly subscribed, is a powerful feature for mobile networks, and LTE/SAE is no exception. A roaming user is connected to the E-UTRAN, MME and S-GW of the visited LTE network. However, LTE/SAE allows the P-GW of either the visited or the home network to be used, as shown in Figure 4. Using the home network’s P-GW allows the user to access the home operator’s services even while in a visited network. A P-GW in the visited network allows a “local breakout” to the Internet in the visited network.

Figure 4. Roaming architecture for 3GPP accesses with P-GW in home network

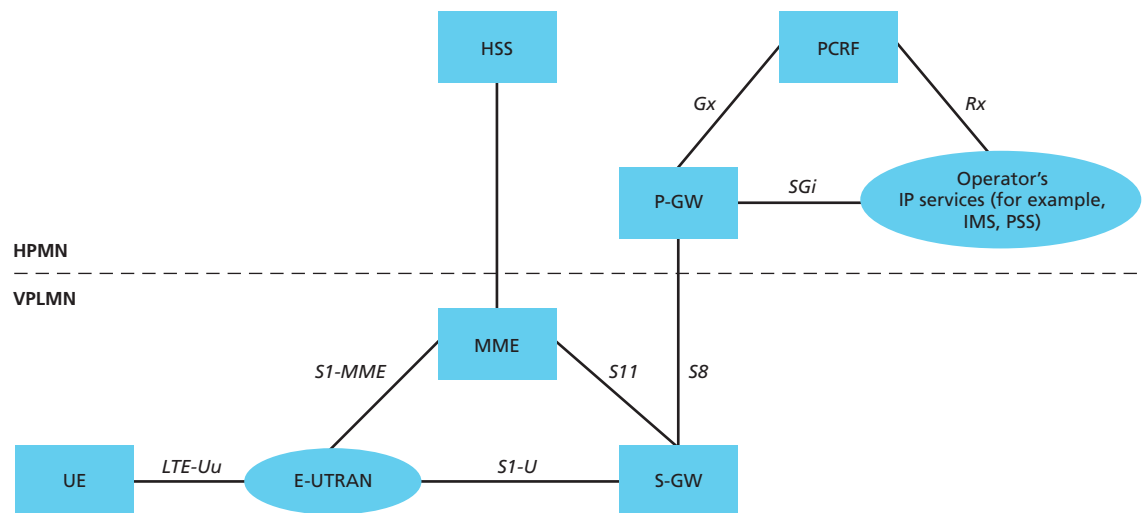

3.4 Interworking with other networks

EPS also supports interworking and mobility (handover) with networks using other Radio Access Technologies (RATs), notably Global System for Mobile Communications (GSM), UMTS, CDMA2000 and WiMAX. The architecture for interworking with 2G and 3G GPRS/UMTS networks is shown in Figure 5. The S-GW acts as the mobility anchor for interworking with other 3GPP technologies such as GSM and UMTS, while the P-GW serves as an anchor allowing seamless mobility to non-3GPP networks such as CDMA2000 or WiMAX. The P-GW may also support a Proxy Mobile Internet Protocol (PMIP)-based interface. More details of the radio interface procedures for interworking are specified in [3] and are also covered in Section 6.6.2.

Figure 5. Architecture for 3G UMTS interworking

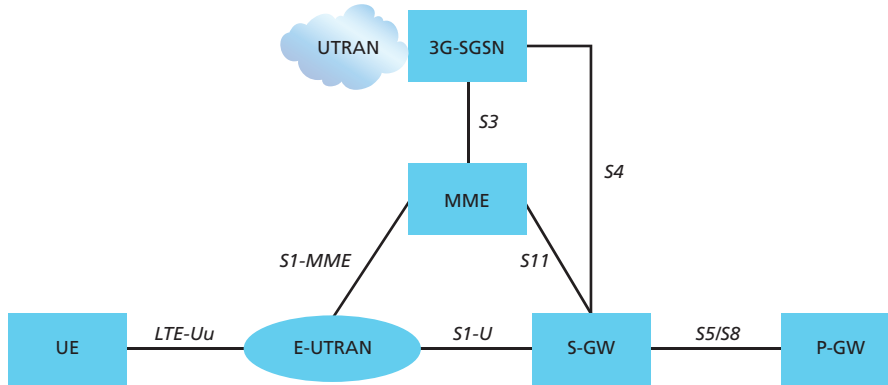

4. Protocol architecture

We outline here the radio protocol architecture of E-UTRAN.

4.1 User plane

An IP packet for a UE is encapsulated in an EPC-specific protocol and tunneled between the P-GW and the eNodeB for transmission to the UE. Different tunneling protocols are used across different interfaces. A 3GPP-specific tunneling protocol called the GPRS Tunneling Protocol (GTP) is used over the CN interfaces, S1 and S5/S8.¹

The E-UTRAN user plane protocol stack is shown in blue in Figure 6, consisting of the Packet Data Convergence Protocol (PDCP), Radio Link Control (RLC) and Medium Access Control (MAC) sublayers that are terminated in the eNodeB on the network side. The respective roles of each of these layers are explained in detail in Chapter 4 of [8].

Figure 6. The E-UTRAN user plane protocol stack

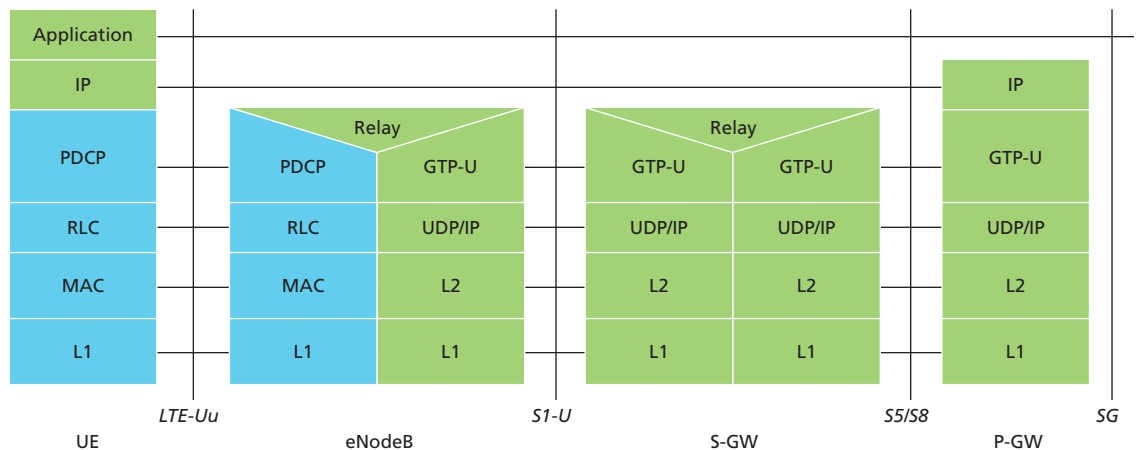

¹ SAE also provides an option to use PMIP on S5/S8. More details on the MIP-based S5/S8 interface can be found in [3].

4.1.1 Data handling during handover

In the absence of any centralized controller node, data buffering during handover due to user mobility in the E-UTRAN must be performed in the eNodeB itself. Data protection during handover is a responsibility of the PDCP layer. The RLC and MAC layers both start afresh in a new cell after handover.

4.2 Control plane

The protocol stack for the control plane between the UE and MME is shown in Figure 7. The blue region of the stack indicates the AS protocols. The lower layers perform the same functions as for the user plane with the exception that there is no header compression function for the control plane.

Figure 7. Control plane protocol stack

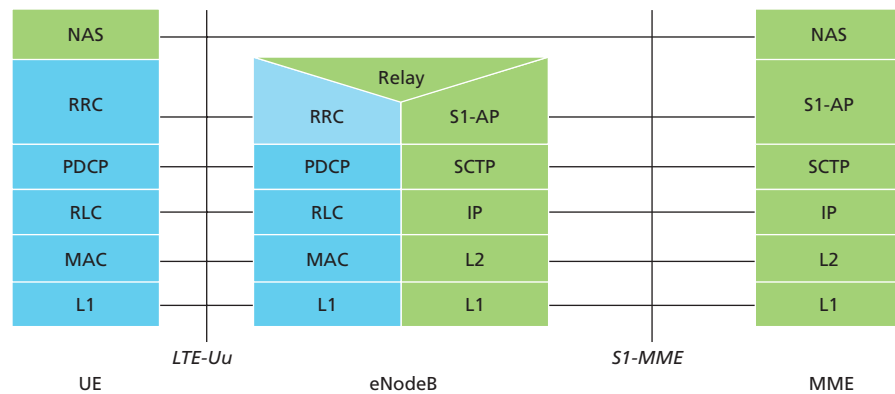

The Radio Resource Control (RRC) protocol is known as “layer 3” in the AS protocol stack. It is the main controlling function in the AS, being responsible for establishing the radio bearers and configuring all the lower layers using RRC signaling between the eNodeB and the UE.

5. Quality of service and EPS bearers

In a typical case, multiple applications may be running in a UE at any time, each one having different quality of service requirements. For example, a UE can be engaged in a VoIP call while at the same time browsing a web page or downloading an FTP file. VoIP has more stringent requirements for QoS in terms of delay and delay jitter than web browsing and FTP, while the latter requires a much lower packet loss rate. In order to support multiple QoS requirements, different bearers are set up within the Evolved Packet System, each being associated with a QoS.

Broadly, bearers can be classified into two categories based on the nature of the QoS they provide:

- Minimum guaranteed bit rate (GBR) bearers that can be used for applications such as VoIP. These have an associated GBR value for which dedicated transmission resources are permanently allocated (for example, by an admission control function in the eNodeB) at bearer establishment or modification. Bit rates higher than the GBR may be allowed for a GBR bearer if resources are available. In such cases, a maximum bit rate (MBR) parameter, which can also be associated with a GBR bearer, sets an upper limit on the bit rate that can be expected from a GBR bearer.
- Non-GBR bearers that do not guarantee any particular bit rate. These can be used for applications such as web browsing or FTP transfer. For these bearers, no bandwidth resources are allocated permanently to the bearer.

In the access network, it is the responsibility of the eNodeB to ensure the necessary QoS for a bearer over the radio interface. Each bearer has an associated QCI, and an Allocation and Retention Priority (ARP).

Each QCI is characterized by priority, packet delay budget and acceptable packet loss rate. The QCI label for a bearer determines how it is handled in the eNodeB. Only a dozen such QCIs have been standardized so that vendors can all have the same understanding of the underlying service characteristics and thus provide corresponding treatment, including queue management, conditioning and policing strategy.

This ensures that an LTE operator can expect uniform traffic-handling behavior throughout the network regardless of the manufacturers of the eNodeB equipment. The set of standardized QCIs and their characteristics (from which the PCRF in an EPS can select) is provided in Table 1 (from Section 6.1.7 in [5]). The QCI table specifies values for the priority handling, acceptable delay budget and packet loss rate for each QCI label.

Table 1. Standardized QCIs for LTE

QCI	RESOURCE TYPE	PRIORITY	PACKET DELAY BUDGET (MS)	PACKET ERROR LOSS RATE	EXAMPLE SERVICES
1	GBR	2	100	10 ⁻²	Conversational voice
2	GBR	4	150	10 ⁻³	Conversational video (live streaming)
3	GBR	5	300	10 ⁻⁶	Non-conversational video (buffered streaming)
4	GBR	3	50	10 ⁻³	Real-time gaming
5	Non-GBR	1	100	10 ⁻⁶	IMS signaling
6	Non-GBR	7	100	10 ⁻³	Voice, video (live streaming), interactive gaming
7	Non-GBR	6	300	10 ⁻⁶	Video (buffered streaming)
8	Non-GBR	8	300	10 ⁻⁶	TCP-based (for example, WWW, e-mail), chat, FTP, p2p file sharing, progressive video and others
9	Non-GBR	9	300	10 ⁻⁶	

The priority and packet delay budget (and to some extent the acceptable packet loss rate) from the QCI label determine the RLC mode configuration (see Section 4.3.1 of [8]) and how the scheduler in the MAC handles packets sent over the bearer (for example, in terms of scheduling policy, queue management policy and rate-shaping policy). For example, a packet with higher priority can be expected to be scheduled before a packet with lower priority. For bearers with a low acceptable loss rate, an acknowledged mode (AM) can be used within the RLC protocol layer to ensure that packets are delivered successfully across the radio interface.

The ARP of a bearer is used for call admission control — that is, to decide whether or not the requested bearer should be established in case of radio congestion. It also governs the prioritization of the bearer for pre-emption with respect to a new bearer establishment request. Once successfully established, a bearer's ARP does not have any impact on the bearer-level packet forwarding treatment (for example, for scheduling and rate control). Such packet forwarding treatment should be solely determined by the other bearer level QoS parameters such as QCI, GBR and MBR.

An EPS bearer has to cross multiple interfaces as shown in Figure 8 — the S5/S8 interface from the P-GW to the S-GW, the S1 interface from the S-GW to the eNodeB, and the radio interface (also known as the “LTE-Uu interface”) from the eNodeB to the UE. Across each interface, the EPS bearer is mapped onto a lower layer bearer, each with its own bearer identity. Each node must keep track of the binding between the bearer IDs across its different interfaces.

An S5/S8 bearer transports the packets of an EPS bearer between a P-GW and an S-GW. The S-GW stores a one-to-one mapping between an S1 bearer and an S5/S8 bearer. The bearer is identified by the GTP tunnel ID across both interfaces.

Figure 8. LTE/SAE bearer across the different interfaces

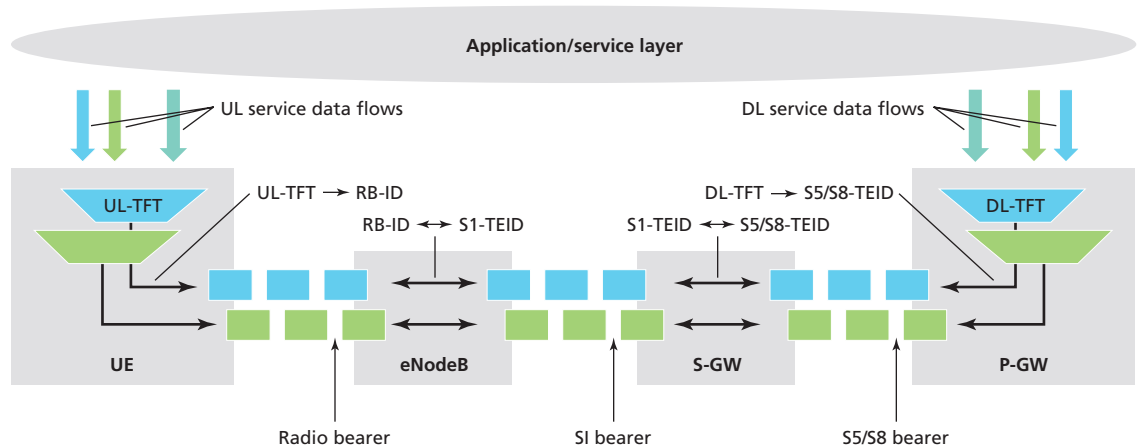

The packets of an EPS bearer are transported by an S1 bearer between an S-GW and an eNodeB, and by a radio bearer [6] between a UE and an eNodeB. An eNodeB stores a one-to-one mapping between a radio bearer ID and an S1 bearer to create the mapping between the two.

IP packets mapped to the same EPS bearer receive the same bearer-level packet forwarding treatment (for example, scheduling policy, queue management policy, rate shaping policy, RLC configuration). In order to provide different bearer-level QoS, a separate EPS bearer must therefore be established for each QoS flow. User IP packets must then be filtered into the appropriate EPS bearers.

Packet filtering into different bearers is based on TFTs. The TFTs use IP header information such as source and destination IP addresses and Transmission Control Protocol (TCP) port numbers to filter packets such as VoIP from web-browsing traffic, so that each can be sent down the respective bearers with appropriate QoS. An Uplink TFT (UL TFT) associated with each bearer in the UE filters IP packets to EPS bearers in the uplink direction. A Downlink TFT (DL TFT) in the P-GW is a similar set of downlink packet filters.

As part of the procedure by which a UE attaches to the network, the UE is assigned an IP address by the P-GW and at least one bearer is established. This is called the default bearer, and it remains established throughout the lifetime of the PDN connection in order to provide the UE with always-on IP connectivity to that PDN. The initial bearer-level QoS parameter values of the default bearer are assigned by the MME, based on subscription data retrieved from the HSS. The PCEF may change these values in interaction with the PCRF or according to local configuration. Additional bearers called dedicated bearers can also be established at any time during or after completion of the attach procedure. A dedicated bearer can be either a GBR or a non-GBR bearer (the default bearer always

has to be a non-GBR bearer since it is permanently established). The distinction between default and dedicated bearers should be transparent to the access network (for example, E-UTRAN). Each bearer has an associated QoS, and if more than one bearer is established for a given UE, then each bearer must also be associated with appropriate TFTs. These dedicated bearers could be established by the network, based for example on a trigger from the IMS domain, or they could be requested by the UE. The dedicated bearers for a UE may be provided by one or more P-GWs.

The bearer-level QoS parameter values for dedicated bearers are received by the P-GW from the PCRF and forwarded to the S-GW. The MME only transparently forwards those values received from the S-GW over the S11 reference point (see Figure 5) to the E-UTRAN.

5.1 Bearer establishment procedure

This section describes a typical end-to-end bearer establishment procedure across the network nodes, as shown in Figure 9, using the functionality described in the above sections. When a bearer is established, the bearers across each of the interfaces discussed above are established.

The PCRF sends a Policy Control and Charging (PCC) Decision Provision message indicating the required QoS for the bearer to the P-GW. The P-GW uses this QoS policy to assign the bearer-level QoS parameters. The P-GW then sends a Create Dedicated Bearer Request message including the QoS and UL TFT to be used in the UE to the S-GW. After the S-GW receives the Create Dedicated Bearer Request message, including bearer QoS, UL TFT and S1-bearer ID, it forwards it to the MME (message 3 in Figure 9).

Figure 9. An example message flow for a LTE/SAE bearer establishment

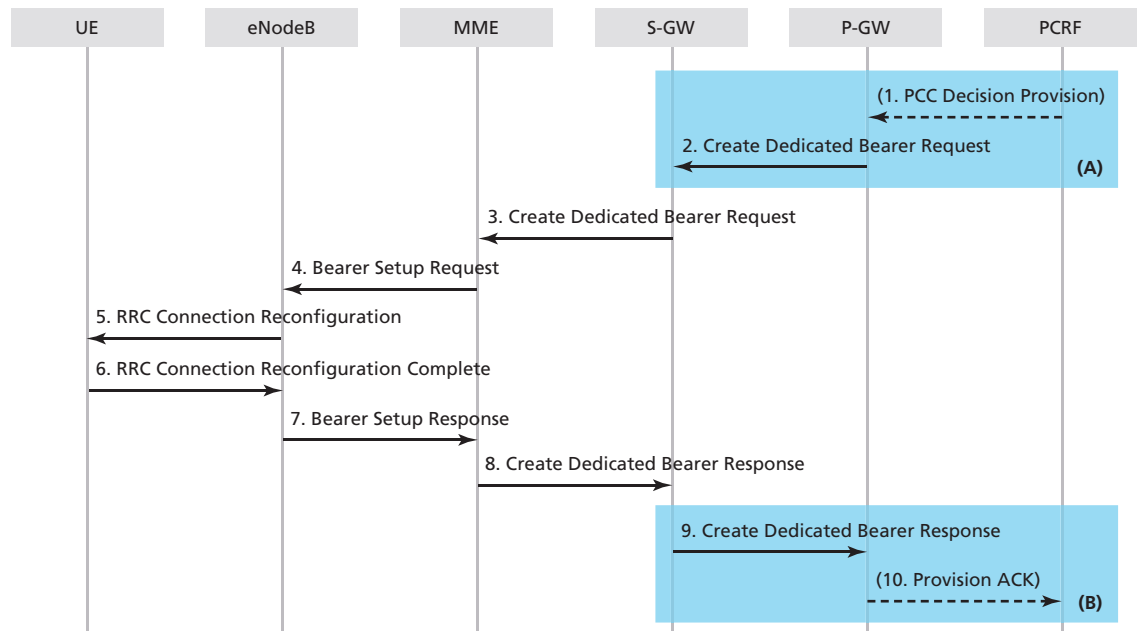

The MME then builds a set of session management configuration information including the UL TFT and the EPS bearer identity and includes it in the Bearer Setup Request message that it sends to the eNodeB (message 4 in Figure 9). Since the session management configuration is NAS information, it is sent transparently by the eNodeB to the UE.

The Bearer Setup Request also provides the QoS of the bearer to the eNodeB; this information is used by the eNodeB for call admission control and also to ensure the necessary QoS by appropriate scheduling of the user's IP packets. The eNodeB maps the EPS bearer QoS to the radio bearer QoS and then signals an RRC Connection Reconfiguration message (including the radio bearer QoS, session management request and EPS radio bearer identity) to the UE to setup the radio bearer (message 5 in Figure 9). The RRC Connection Reconfiguration message contains all the configuration parameters for the radio interface. These are mainly for the configuration of the layer 2 (the PDCP, RLC and MAC parameters), but also contain the layer 1 parameters required for the UE to initialize the protocol stack.

Messages 6 to 10 are the corresponding response messages to confirm that the bearers have been correctly set up.

6. The E-UTRAN network interfaces: S1 interface

The provision of self-optimizing networks (SONs) is one of the key objectives of LTE. Indeed, self-optimization of the network is a high priority for network operators as a tool to derive the best performance from the network in a cost-effective manner, especially in changing radio propagation environments. Hence SON has been placed as a cornerstone of the LTE system from the beginning and is the concept around which all S1 and X2 procedures have been designed.

The S1 interface connects the eNodeB to the EPC. It is split into two interfaces, one for the control plane and the other for the user plane. The protocol structure for the S1 and the functionality provided over S1 are discussed in more detail below.

6.1 Protocol structure over S1

The protocol structure over S1 is based on a full IP transport stack with no dependency on legacy SS7² network configuration as used in GSM or UMTS networks. This simplification provides one expected area of savings on operational expenditure when LTE networks are deployed.

6.1.1 Control plane

Figure 10 shows the protocol structure of the S1 control plane, which is based on the well-known Stream Control Transmission Protocol / IP (SCTP/IP) stack.

The SCTP protocol is well known for its advanced features inherited from TCP that ensure the required reliable delivery of the signaling messages. In addition it makes it possible to benefit from improved features such as the handling of multi-streams to implement transport network redundancy easily and avoid head-of-line blocking or multi-homing. (See IETF RFC 4960 [7].)

An area of simplification in LTE (as compared to the UMTS Iu interface, for example) is the direct mapping of S1 Application Protocol (S1-AP) on top of SCTP. This results in a simplified protocol stack with no intermediate connection management protocol, since the individual connections are handled directly at the application layer. Multiplexing takes place between S1-AP and SCTP whereby each stream of an SCTP association is multiplexed with the signaling traffic of multiple individual connections.

Figure 10. S1 control plane protocol stack

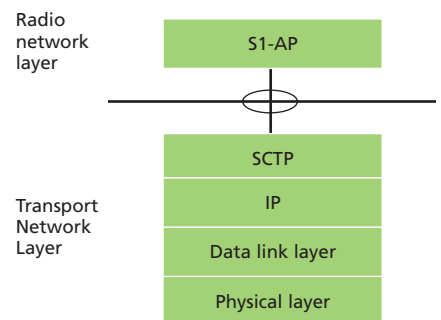

² Signaling System #7 (SS7) is a communications protocol defined by the International Telecommunication Union Telecommunication Standardization Sector with a main purpose of setting up and tearing down telephone calls. Other uses include Short Message Service, number translation, prepaid billing mechanisms and many other services.

LTE has also built flexibility into the lower layer protocols, giving the operator full optionality regarding the choice of IP version and the data link layer. For example, this enables the operator to start deployment using IP version 4 with the data link tailored to the network deployment scenario.

6.1.2 User plane

Figure 11 gives the protocol structure of the S1 user plane, based on the GTP/UDP/IP stack, which is already well known from UMTS networks.

One of the advantages of using GPRS Tunneling Protocol-User plane (GTP-U) is its inherent facility to identify tunnels and to facilitate intra-3GPP mobility.

The IP version number and the data link layer have been left fully optional, as for the control plane stack.

A transport bearer is identified by the GTP tunnel endpoints and the IP address (source Tunneling End ID [TEID]), destination TEID, source IP address, destination IP address). The S-GW sends downlink packets of a given bearer to the eNodeB IP address (received in S1-AP) associated to that particular bearer. Similarly, the eNodeB sends upstream packets of a given bearer to the EPC IP address (received in S1-AP) associated with that particular bearer.

Vendor-specific traffic categories (for example, real-time traffic) can be mapped onto Differentiated Services (DiffServ) code points (for example, expedited forwarding) by network operations and maintenance (O&M) configuration to manage QoS differentiation between the bearers.

6.2 Initiation over S1

The initialization of the S1-MME control plane interface starts with the identification of the MMEs to which the eNodeB must connect, followed by the setting up of the Transport Network Layer (TNL).

With the support of the S1-flex function in LTE, an eNodeB must initiate an S1 interface toward each MME node of the pool area to which it belongs. The list of MME nodes of the pool together with an initial corresponding remote IP address can be directly configured in the eNodeB at deployment (although other means may also be used). The eNodeB then initiates the TNL establishment with that IP address. Only one SCTP association is established between one eNodeB and one MME.

During the establishment of the SCTP association, the two nodes negotiate the maximum number of streams that will be used over that association. However, multiple pairs of streams are typically used in order to avoid the head-of-line blocking issue mentioned above. (Note that a stream is unidirectional and therefore pairs must be used.) Among these pairs of streams, one must be reserved by the two nodes for the signaling of the common procedures (that is, those that are not specific to one UE). The other streams are used for the sole purpose of the dedicated procedures (that is, those that are specific to one UE).

Once the TNL has been established, some basic application-level configuration data for the system operation is automatically exchanged between the eNodeB and the MME through an S1 Setup procedure initiated by the eNodeB. This procedure constitutes one example of a network self-configuration process provided in LTE to reduce the configuration effort for network operators compared to the more usual manual configuration procedures of earlier systems.

Figure 11. S1-U user plane protocol stack

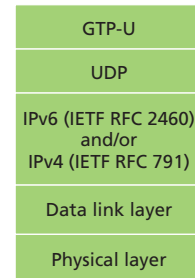

An example of basic application data that can be automatically configured through the S1 Setup procedure is the tracking area identities, which correspond to the zones in which UEs will be paged. Their mapping to eNodeBs must remain consistent between the E-UTRAN and the EPC. Once the tracking area identities have been configured within each eNodeB, they are sent automatically to all the relevant MME nodes of the pool area within the S1 Setup Request message. The same applies for the broadcast list of PLMNs that is used when a network is being shared by several operators (each having its own PLMN-ID that needs to be broadcast for the UEs to recognize it). This saves a significant amount of configuration effort in the CN, avoids the risk of human error, and ensures that the E-UTRAN and EPC configurations regarding tracking areas and PLMNs are aligned.

Once the S1 Setup procedure has been completed, the S1 interface is operational.

6.3 Context management over S1

Within each pool area, a UE is associated with one particular MME for all its communications during its stay in this pool area. This creates a context in this MME for the UE. This particular MME is selected by the NAS Node Selection Function (NNSF) in the first eNodeB from which the UE entered the pool.

Whenever the UE becomes active (that is, makes a transition from idle to active mode) under the coverage of a particular eNodeB in the pool area, the MME provides the UE context information to this eNodeB using the Initial Context Setup Request message. (See Figure 12.) This enables the eNodeB in turn to create a context and manage the UE for the duration of its activity in active mode.

Even though the setup of bearers is otherwise relevant to a dedicated bearer management procedure described below, the creation of the eNodeB context by the Initial Context Setup procedure also includes the creation of one or several bearers including the default bearer.

At the next transition back to idle mode following a UE Context Release Command message sent from the MME, the UE context in the eNodeB is erased and only the UE context in the MME remains.

6.4 Bearer management over S1

LTE uses dedicated procedures independently covering the setup, modification and release of bearers. For each bearer requested to be setup, the transport layer address and the tunnel endpoint are provided to the eNodeB in the Bearer Setup Request message to indicate the termination of the bearer in the S-GW where uplink user plane data must be sent. Conversely, the eNodeB indicates in the Bearer Setup Response message the termination of the bearer in the eNodeB where the downlink user plane data must be sent. For each bearer, the QoS parameters (see Section 5 above) requested for the bearer are also indicated. Independently of the standardized QCI values, it is also still possible to use extra proprietary QCI values for the fast introduction of new services if vendors and operators agree upon them.

6.5 Paging over S1

As mentioned in Section 6.3, in order to reestablish a connection toward a UE in idle mode, the MME distributes a paging request to the relevant eNodeBs based on the tracking areas where the UE is expected to be located. When it receives the Paging Request message, the eNodeB sends a page over the radio interface in the cells that are contained within one of the tracking areas provided in that message.

Figure 12. Initial Context Setup procedure

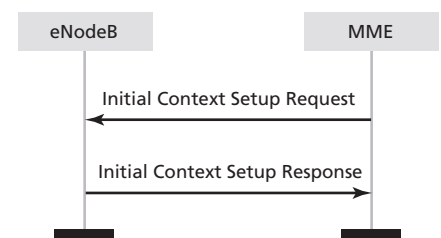

The UE is normally paged using its S-TMSI. The Paging Request message also contains a UE identity index value in order for the eNodeB to calculate the paging occasions at which the UE will switch on its receiver to listen for paging messages. (See Section 3.4 of [8].)

6.6 Mobility over S1

LTE/SAE supports mobility within LTE/SAE as well as mobility to other systems using both 3GPP and non-3GPP technologies. The mobility procedures over the radio interface are described in Section 3.2 of [8]. These mobility procedures also involve the network interfaces. The sections below discuss the procedures over S1 to support mobility.

6.6.1 Intra-LTE mobility

There are two types of handover procedure in LTE for UEs in active mode: the S1 and X2 handover procedures.

For intra-LTE mobility, that is, mobility within the LTE system, the X2-handover procedure is normally used for inter-eNodeB handover (described in Section 7.3). However, when there is no X2 interface between the two eNodeBs, or if the source eNodeB has been configured to initiate handover towards a particular target eNodeB through the S1 interface, then an S1-handover will be triggered.

The S1-handover procedure, shown in Figure 13, has been designed in a similar way to the UMTS Serving Radio Network Subsystem (SRNS) relocation procedure: it consists of a preparation phase, where the CN resources are prepared at the target side (steps 2 to 8), followed by an execution phase (steps 8 to 12) and a completion phase (after step 13).

Figure 13. S1-based handover procedure

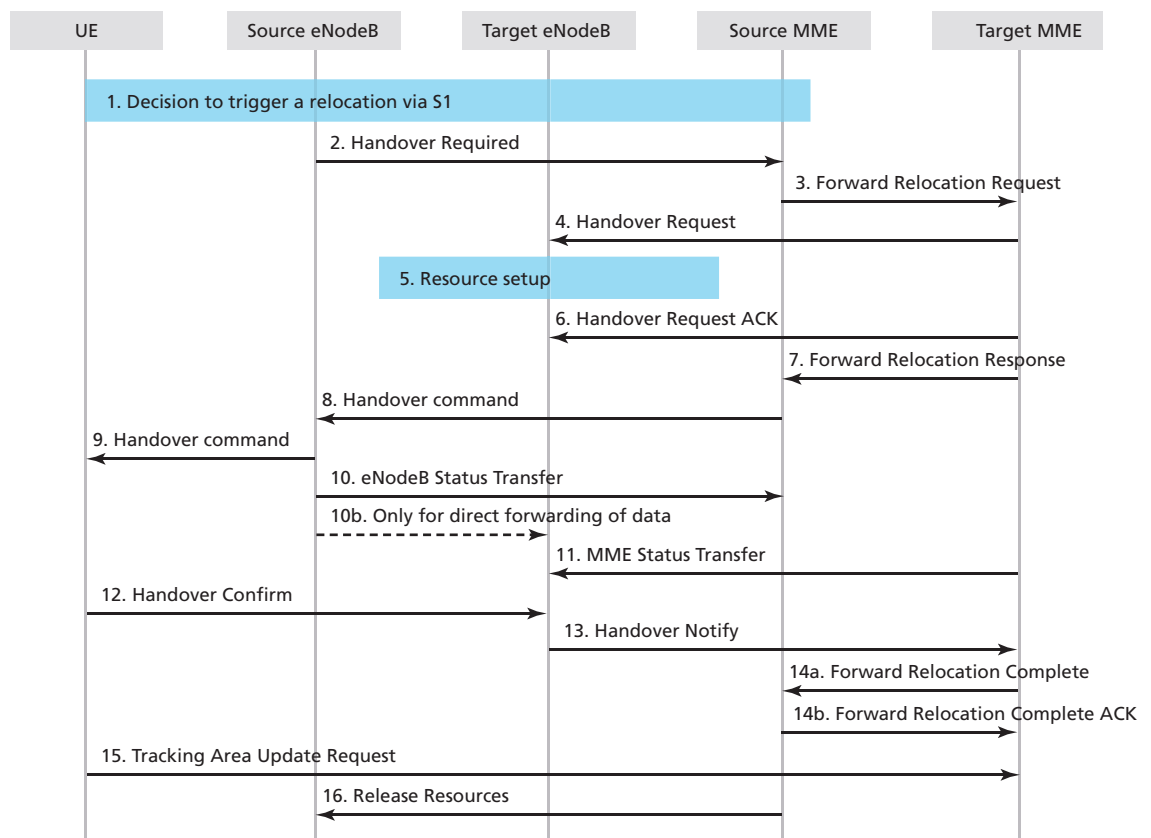

Compared to UMTS, the main difference is the introduction of the Status Transfer message sent by the source eNodeB (steps 10 and 11). This message has been added in order to carry some PDCP status information that is needed at the target eNodeB in cases when PDCP status preservation applies for the S1-handover (see Section 4.2.4 of [8]); this is in alignment with the information that is sent within the X2 Status Transfer message used for the X2-handover. (See below.) As a result of this alignment, the handling of the handover by the target eNodeB as seen from the UE is exactly the same, regardless of the type of handover (S1 or X2) being used.

The Status Transfer procedure is assumed to be triggered in parallel with the start of data forwarding after the source eNodeB has received the handover command message from the source MME. This data forwarding can be either direct or indirect, depending on the availability of a direct path for the user plane data between the source eNodeB and the target eNodeB.

The Handover Notify message (step 13), which is sent later by the target eNodeB when the arrival of the UE at the target side is confirmed, is forwarded by the MME to trigger the update of the path switch in the S-GW toward the target eNodeB. In contrast to the X2-handover, the message is not acknowledged and the resources at the source side are released later upon reception of a Release Resource message directly triggered from the source MME (step 17 in Figure 13).

6.6.2 Inter-Radio Access Technology mobility

One key element of the design of the first release of LTE is the need to co-exist with other technologies.

For mobility from LTE toward UMTS, the handover process can reuse the S1-handover procedures described above, with the exception of the Status Transfer message, which is not needed at steps 10 and 11 since no PDCP context is continued.

For mobility toward CDMA2000, dedicated uplink and downlink procedures have been introduced in LTE. They essentially aim at tunneling the CDMA2000 signaling between the UE and the CDMA2000 system over the S1 interface, without being interpreted by the eNodeB on the way. The Uplink S1 CDMA2000

Tunneling message shown in Figure 14 also includes the Radio Access Technology (RAT) type in order to identify the CDMA2000 RAT with which the tunneled CDMA2000 message is associated in order for the message to be routed to the correct node within the CDMA2000 system.

Figure 14. Uplink S1 CDMA2000 tunneling procedure

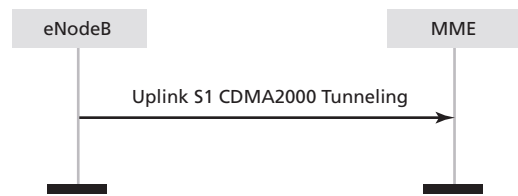

6.7 Load management over S1

Three types of load management procedures apply over S1: a normal load balancing procedure to distribute the traffic, an overload procedure to overcome a sudden peak in the loading and a load rebalancing procedure to partially/fully offload an MME.

The MME load balancing procedure aims to distribute the traffic to the MMEs in the pool evenly according to their respective capacities. To achieve this goal, the procedure relies on the normal NNSF present in each eNodeB as part of the S1-flex function. (See Section 6.3.) Provided that suitable weight factors corresponding to the capacity of each MME node are available in the eNodeBs

beforehand, a weighted NNSF done by each and every eNodeB in the network normally achieves a statistically balanced distribution of load among the MME nodes without further action. However, specific actions are still required for some particular scenarios:

- If a new MME node is introduced (or removed), it may be necessary temporarily to increase (or decrease) the weight factor normally corresponding to the capacity of this node in order to make it catch more (or less) traffic at the beginning until it reaches an adequate level of load.
- In case of an unexpected peak in the loading, an Overload message can be sent over the S1 interface by the overloaded MME. When received by an eNodeB, this message calls for a temporary restriction of a certain type of traffic. An MME can adjust the reduction of traffic it desires by defining the number of eNodeBs to which it sends the Overload message and by defining the types of traffic subject to restriction.
- Finally, if the MME wants to rapidly force the offload of some or all of its UEs, it will use the rebalancing function. This function forces the UEs to reattach to another MME by using a specific “cause value” in the UE Release Command S1 message. In a first step it applies to idle mode UEs and in a second step it may also apply to UEs in connected mode (if full MME offload is desired, for example, for maintenance reasons).

7. The E-UTRAN network interfaces: X2 interface

The X2 interface is used to interconnect eNodeBs. The protocol structure for the X2 interface and the functionality provided over X2 are discussed below.

7.1 Protocol structure over X2

The control and user plane protocol stacks over the X2 interface, shown in figures 15 and 16 respectively, are the same as those for the S1 interface, with the exception that X2-AP is substituted for S1-AP. This also reaffirms that the choice of the IP version and the data link layer are fully optional.

The use of the same protocol structure over both interfaces provides advantages such as simplifying the data forwarding operation.

Figure 15. X2 signaling bearer protocol stack

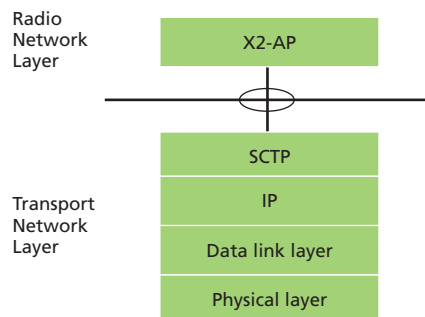
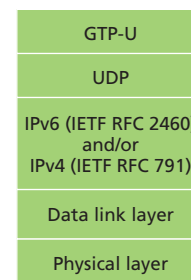

Figure 16. Transport Network Layer for data streams over X2



7.2 Initiation over X2

The X2 interface may be established between one eNodeB and some of its neighbor eNodeBs in order to exchange signaling information when needed. However, a full mesh is not mandated in an E-UTRAN network. Two types of information may typically need to be exchanged over X2 to drive the establishment of an X2 interface between two eNodeBs: load- or interference-related information (see Section 7.4) and handover-related information (see mobility in Section 7.3).

Because these two types of information are fully independent of one another, it is possible that an X2 interface may be present between two eNodeBs for the purpose of exchanging load or interference information, even though the X2-handover procedure is not used to handover UEs between those eNodeBs. In such a case, the S1-handover procedure is used instead.

The initialization of the X2 interface starts with the identification of a suitable neighbor followed by the setting up of the TNL.

The identification of a suitable neighbor may be done by configuration or alternatively by a function known as the automatic neighbor relation function (ANRF). This function makes use of the UEs to identify the useful neighbor eNodeBs: an eNodeB may ask a UE to read the global cell identity from the broadcast information of another eNodeB for which the UE has identified the physical cell identity (PCI) during the new cell identification procedure. (See Section 7.2 of [8].) The ANRF is another example of a SON process introduced successfully in LTE. Through this self-optimizing process, UEs and eNodeB measurements are used to auto-tune the network.

Once a suitable neighbor has been identified, the initiating eNodeB can set up the TNL using the X2 IP address of this neighbor, either as retrieved from the network or locally configured. In particular, a SON-configuration dedicated procedure over S1 termed the eNB Configuration Transfer procedure has been designed to enable the initiating eNodeB to directly request over the S1 interface the X2 IP address of a discovered neighbor eNodeB to be used for X2 establishment. This network solution through the S1 interface may avoid the need for an operator to use other more complex network solutions such as the deployment of DNS servers.

After the TNL has been set up, the initiating eNodeB must trigger the X2 Setup procedure. This procedure enables an automatic exchange of application level configuration data relevant to the X2 interface, similar to the S1 Setup procedure already described in Section 6.2. For example, each eNodeB reports to a neighbor eNodeB, using the X2 Setup Request message, information about each cell it manages, such as the cell's physical identity, the frequency band, the tracking area identity and/or the associated PLMNs.

This automatic data exchange in the X2 Setup procedure is also the core of another SON feature: the automatic self-configuration of the PCIs. Under this new SON feature, the O&M system can provide the eNodeBs with either a list of possible PCI values to use or a specific PCI value. In the first case, in order to avoid collisions, the eNodeB should use a PCI that is not already used in its neighborhood. Because the PCI information is included in the LTE X2 Setup procedure, while detecting a neighbor cell by the ANR function, an eNodeB can also discover all the PCI values used in the neighborhood of that cell and consequently eliminate those values from the list of suitable PCIs to start with.

Once the X2 Setup procedure has been completed, the X2 interface is operational.

7.3 Mobility over X2

Handover through the X2 interface is triggered by default for intra-LTE mobility unless there is no X2 interface established or the source eNodeB is configured to use S1-handover instead. The X2-handover procedure is illustrated in Figure 17. Like S1-handover, it is also composed of a preparation phase (steps 4 to 6), an execution phase (steps 7 to 9) and a completion phase (after step 9).

The key features of X2-handover for intra-LTE handover are:

- The handover is directly performed between two eNodeBs, making the preparation phase quick.
- Data forwarding may be operated per bearer in order to minimize data loss.
- The MME is only informed at the end of the handover procedure when the handover is successful, in order to trigger the path switch.
- The release of resources at the source side is directly triggered from the target eNodeB.

For those bearers requiring in-sequence delivery of packets, the Status Transfer message (step 8) provides the sequence number (SN) and the Hyper Frame Number (HFN) that the target eNodeB should assign to the first packet with no SN yet assigned that it must deliver. This first packet can either be one received over the target S1 path or one received over X2, if data forwarding over X2 is used. (See below.) When the source eNodeB sends the Status Transfer message, it freezes its transmitter/receiver status, that is, it stops assigning PDCP SNs to downlink packets and stops delivering uplink packets to the EPC.

Mobility over X2 can be categorized according to its resilience to packet loss: the handover can be termed “seamless” if it minimizes the interruption time during the move of the UE or “lossless” if it tolerates no loss of packets at all. These two modes use data forwarding of user plane downlink packets. The source eNodeB may decide to operate one of these two modes on a per-EPS-bearer basis, based on the QoS received over S1 for this bearer (see Section 6.4) and the service at stake.

7.3.1 Seamless handovers

If the source eNodeB selects the seamless mode for one bearer, it proposes to the target eNodeB in the Handover Request message to establish a GTP tunnel to operate the downlink data forwarding. If the target eNodeB accepts, it indicates in the Handover Request ACK message the tunnel endpoint where the forwarded data is expected to be received. The tunnel endpoint may be different from the one set up as the termination point of the new bearer established over the target S1.

Figure 17. X2-based handover procedure

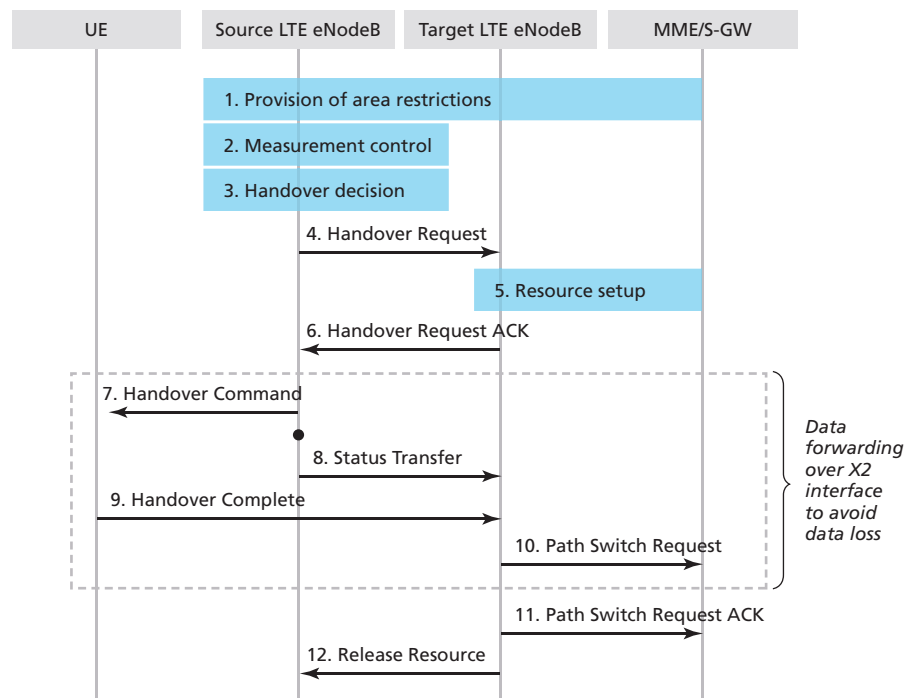

Upon receipt of the Handover Request ACK message, the source eNodeB can start forwarding the freshly arriving data over the source S1 path toward the indicated tunnel endpoint in parallel to sending the handover trigger to the UE over the radio interface. The forwarded data is thus available at the target eNodeB to be delivered to the UE as early as possible.

When forwarding is in operation and in-sequence delivery of packets is required, the target eNodeB is assumed to first deliver the packets forwarded over X2 before delivering the ones received over the target S1 path, once the S1 path switch has been done. The end of the forwarding is signaled over X2 to the target eNodeB by the reception of “special GTP packets” that the S-GW has inserted over the source S1 path just before switching this S1 path; these are then forwarded by the source eNodeB over X2 like any other regular packets.

7.3.2 Lossless handovers

If the source eNodeB selects the lossless mode for one bearer, it will additionally forward over X2 those user plane downlink packets that it has PDCP-processed but that are still buffered locally because they have not yet been delivered and acknowledged by the UE. These packets are forwarded together with their assigned PDCP SN included in a GTP extension header field. They are sent over X2 prior to the fresh arriving packets from the source S1 path. The same mechanisms described above for the seamless handover are used for the GTP tunnel establishment. The end of forwarding is also handled in the same way, since in-sequence packet delivery applies to lossless handovers. In addition, the target eNodeB must ensure that all the packets, including the ones received with sequence number over X2, are delivered in sequence to the target side. Further details of seamless and lossless handover are described in Section 4.2 of [8].

A new feature in LTE is the optimization of the radio by selective retransmission. When lossless handover is used, the target eNodeB may not deliver over the radio interface some of the forwarded downlink packets received over X2 if it is informed by the UE that these packets have already been received at the source side. This is called downlink selective retransmission.

Similarly in the uplink, the target eNodeB may not wish the UE to retransmit packets already received earlier at the source side by the source eNodeB, for example, to avoid wasting radio resources. To use uplink selective retransmission, the source eNodeB forwards the user plane uplink packets that it has received out of sequence to the target eNodeB, over a new GTP tunnel. The target eNodeB must first request the source eNodeB to establish the new forwarding tunnel by including a GTP tunnel endpoint where it expects the forwarded uplink packets to be received in the Handover Request ACK message. If possible, the source eNodeB then indicates in the Status Transfer message for this bearer, the list of SNs corresponding to the expected forwarded packets. This list helps the target eNodeB inform the UE earlier of the packets that are not to be retransmitted, making the overall uplink selective retransmission scheme faster .

7.3.3 Multiple preparation

Another new feature of the LTE handover procedure compared to UMTS is multiple preparation. This feature enables the source eNodeB to trigger the handover preparation procedure towards multiple candidate target eNodeBs. Even though only one of the candidates is indicated as target to the UE, this makes recovery faster in case the UE fails to attach to the target and connects to one of the other prepared candidate eNodeBs instead. The source eNodeB receives only one Release Resource message from the final selected eNodeB.

Regardless of whether multiple or single preparation is used, the handover can be canceled during or after the preparation phase. If the multiple preparation feature is used, it is for example recommended that upon reception of the Release Resource message the source eNodeB triggers a Cancel procedure toward each of the non-selected prepared eNodeBs.

7.4 Load and interference management over X2

The exchange of load information between eNodeBs is of key importance in the flat architecture used in LTE, as there is no central RRM node as was the case, for example, in UMTS with the Radio Network Controller (RNC). The exchange of load information falls into two categories depending on the purpose it serves.

- The exchange of load information can be used for the X2 load balancing process, in which case the relevant frequency of exchange is rather low (in the order of seconds);
- The exchange of load information can be used to optimize some RRM processes, such as interference coordination (as discussed in Section 12.5 of [8]), in which case the frequency of exchange is rather high (in the order of tens of milliseconds).

7.4.1 Load balancing

Like the ANRF SON function described in Section 7.2, load balancing is another aspect of SON built into the design of LTE. The objective of load balancing is to counteract local traffic load imbalance between neighboring cells with the aim of improving the overall system capacity. One solution is to optimize the cell reselection/handover parameters (such as thresholds and hysteresis) between neighboring cells autonomously upon detection of an imbalance.

In order to detect an imbalance, it is necessary to compare the load of the cells and therefore to exchange information about them between neighboring eNodeBs. The cell load information exchanged can be of different types: radio measurements corresponding to the usage of physical resource blocks, possibly partitioned into real-time and non-real-time traffic; or generic measurements representing non-radio-related resource usage such as processing or hardware occupancy.

A client-server mechanism is used for the load information exchange: the Resource Status Response and Update messages are used to report the load information over the X2 interface between a requesting eNodeB (client) and the eNodeBs that have subscribed to this request (servers). The reporting of the load is periodic and according to the periodicity expressed in the Resource Status Request message that triggered the procedure.

7.4.2 Interference management

A separate load indication procedure is used over the X2 interface for the exchange of load information related to interference management as shown in Figure 18. As these measurements have direct influence on some RRM real-time processes, the frequency of reporting using this procedure may be high.

For the uplink interference, two indicators can be provided within the load indication message: a “High Interference Indicator” and an “Overload Indicator.” The usage of these indicators is explained in Section 12.5 of [8].

Figure 18. Load indication over X2 interface

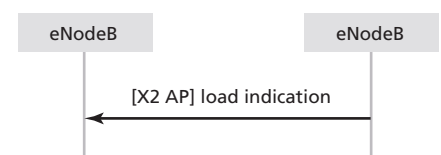

7.5 UE historical information over X2

Historical UE information constitutes another example of a feature designed to support SON built into the design of LTE. It is embedded within the X2-handover procedure. Historical UE information consists, for example, of the last few cells visited by the UE, together with the time spent in each one. This information is propagated from one eNodeB to another within the Handover Request messages and can be used to determine the occurrence of ping-pong between two or three cells for instance. The length of the history information can be configured for more flexibility.

More generally, the historical UE information consists of some RRM information that is passed from the source eNodeB to the target eNodeB within the Handover Request message to assist the RRM management of a UE or of a cell. The information can be partitioned into two types:

- UE RRM-related information, passed over X2 within the RRC transparent container
- Cell RRM-related information, passed over X2 directly as an information element of the X2-AP Handover Request message itself

8. Summary

In this paper the mechanisms by which the Evolved Packet System provides user equipment with IP connectivity to the packet data network have been outlined.

It has been shown how the EPS supports multiple data flows with different quality of service per UE for applications that need guaranteed delay and bit rate such as VoIP as well as best effort applications such as web browsing.

Further, an overview of the EPS network architecture has been presented, including the functions provided by the E-UTRAN access network and the evolved packet CN. It can be seen that the concept of EPS bearers, together with their associated QoS attributes, provide a powerful tool for the provision of a variety of simultaneous services to the end user.

From the perspective of the network operator, the LTE system breaks new ground in terms of its degree of support for self-optimization and self-configuration of the network through the X2, S1 and Uu interfaces, to facilitate deployment.

9. Abbreviations

3GPP	Third-Generation Partnership Project	GPRS	general packet radio service
AM	acknowledged mode	GSM	Global System for Mobile Communications
ANRF	automatic neighbor relation function	GTP	GPRS Tunneling Protocol
AP	Application Protocol	GTP-U	GPRS Tunneling Protocol-User plane
APN	access point name	HFN	Hyper Frame Number
ARP	Allocation and Retention Priority	HSS	Home Subscriber Server
AS	Access Stratum	IETF	Internet Engineering Task Force
AUC	authentication center	IMS	IP Multimedia Subsystem
CN	core network	IP	Internet Protocol
DiffServ	Differentiated Services	LTE	Long Term Evolution
DL TFT	Downlink TFT	MAC	Medium Access Control
DNS	Domain Name System	MBR	maximum bit rate
ECM	EPS Connection Management	MME	Mobility Management Entity
EPC	Evolved Packet Core	NAS	Non Access Stratum
EPS	Evolved Packet System	NNSF	NAS Node Selection Function
eNodeB	Evolved NodeB	O&M	operation and maintenance
E-UTRAN	Evolved UTRAN	PCC	Policy Control and Charging
GBR	guaranteed bit rate		

PCEF	Policy Control Enforcement Function	SCTP	Stream Control Transmission Protocol
PCI	physical cell identity	S-GW	Serving Gateway
PCRF	Policy Control and Charging Rules Function	SN	sequence number
PDCP	Packet Data Convergence Protocol	SON	self-optimizing networks
PDN	packet data network	SRNS	Serving Radio Network Subsystem
P-GW	PDN Gateway	S-TMSI	SAE Temporary Mobile Subscriber Identity
PLMN	public land mobile network	TA	tracking area
PMIP	Proxy Mobile Internet Protocol	TCP	Transmission Control Protocol
QCI	QoS class identifier	TEID	Tunneling End ID
QoS	quality of service	TFT	Traffic Flow Template
RAN	radio access network	TNL	Transport Network Layer
RAT	Radio Access Technology	UE	user equipment
RLC	Radio Link Control	UL TFT	Uplink TFT
RRC	Radio Resource Control	UMTS	Universal Mobile Telecommunications System
RRM	Radio Resource Management	UTRAN	UMTS Terrestrial Radio Access Network
SAE	System Architecture Evolution	VoIP	Voice over IP

The list above covers the abbreviations used in this paper. A comprehensive list of abbreviations relevant to LTE, together with concise explanations of each, can be found in [9].

10. Contacts

For more information on Alcatel-Lucent's LTE solution, please visit www.alcatel-lucent.com or contact your Customer Team representative.

You can also contact Alcatel-Lucent Public Relations:

Christine De Monfreid

Public Relations

Christine.De_Monfreid@alcatel-lucent.fr

+33 1 3077 5914

11. References

- [1] 3GPP Technical Specification 24.301, Non-Access-Stratum (NAS) protocol for Evolved Packet System (EPS); Stage 3 (Release 8), www.3gpp.org.
- [2] 3GPP Technical Specification 33.401, System Architecture Evolution (SAE): Security Architecture (Release 8) , www.3gpp.org.
- [3] 3GPP Technical Specification 23.402, Architecture enhancements for non-3GPP accesses (Release 8), www.3gpp.org.
- [4] 3GPP Technical Specification 29.060, General Packet Radio Service (GPRS); GPRS Tunneling Protocol (GTP) across the Gn and Gp interface (Release 8), www.3gpp.org.
- [5] 3GPP Technical Specification 23.203, Policy and charging control architecture (Release 8), www.3gpp.org.
- [6] 3GPP Technical Specification 36.300, Evolved Universal Terrestrial Radio Access (E-UTRA) and Evolved Universal Terrestrial Radio Access Network (E-UTRAN); Overall description; Stage 2 (Release 8), www.3gpp.org.
- [7] Request for Comments 4960, The Internet Engineering Task Force (IETF), Network Working Group, Stream Control Transmission Protocol, <http://www.ietf.org>.
- [8] S. Sesia, I. Toufik, M. Baker (eds), LTE – The UMTS Long Term Evolution: From Theory to Practice, Wiley, 2009
- [9] S. Sesia, I. Toufik, M. Baker, LTE – The UMTS Long Term Evolution: A Pocket Dictionary of Acronyms, Wiley, 2009, www.wiley.com/go/sesia_theumts.

www.alcatel-lucent.com Alcatel, Lucent, Alcatel-Lucent and the Alcatel-Lucent logo are trademarks of Alcatel-Lucent. All other trademarks are the property of their respective owners. The information presented is subject to change without notice. Alcatel-Lucent assumes no responsibility for inaccuracies contained herein. Copyright © 2009 Alcatel-Lucent. All rights reserved.
CPG05990904 (12)

